

MMC ELECTRIC COMPANY PVT. LTD.

Admin. Off.: 109 / C, Sanjay Building No. 5, Mittal Estate, Sir M. V. Road, Andheri (E), Mumbai - 400 059, India  
 Tel. +91-22-6692 0902 / 6692 0903 • Fax: +91-22-40260904 • e-mail: sales@dynafluxindia.com • Website: www.dynafluxindia.com

### DYNAFLUX FHP AC INDUCTION MOTOR

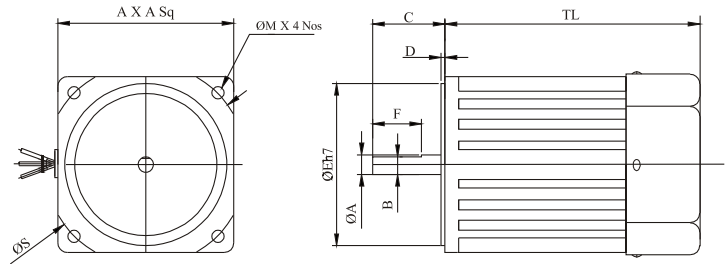

MECHANICAL SPECIFICATIONS.										
WATTS	A x A Sq	A	B	C	D	E	F	ØM	ØS	LT
25	80 X 80	8	7	32	2	73	25	5.5	94	111
40	90 X 90	10	9	37	2	83	25	6.5	104	126
60	90 X 90	12	11	37	2	83	25	6.5	104	130
90	90 X 90	12	11	37	2	83	25	6.5	104	145
120	90 X 90	12	11	37	2	83	25	6.5	104	145
180	90 X 90	12	11	37	2	83	25	6.5	104	165

ELECTRICAL SPECIFICATIONS.														
WATTS	VOLTAGE			FREQUENCY Hz	CURRENT			TORQUE Kg-cm	SPEED rpm	CAPACITOR µF	DUTY CYCLE	INSULATION CLASS	ENCL.	WEIGHT (KG)
	VAC 1	VAC 2	VAC 3		A1	A2	A3							
25	3φ 220	1φ 220	3φ 415	50	0.3	0.25	0.16	1.95	1300	1.5	S1	B	TENV	1.8
40	3φ 220	1φ 220	3φ 415	50	0.38	0.45	0.19	3	1300	2.5	S1	B	TENV	2.5
60	3φ 220	1φ 220	3φ 415	50	0.5	0.63	0.25	4.5	1300	3.5	S1	B	TEFC	2.5
90	3φ 220	1φ 220	3φ 415	50	0.66	0.9	0.34	6.8	1300	6.0	S1	B	TEFC	3.3
120	3φ 220	1φ 220	3φ 415	50	0.88	1.0	0.45	9	1300	6.0	S1	B	TEFC	3.3
180	3φ 220	1φ 220	3φ 415	50	1.2	1.3	0.60	13.5	1300	6.0	S1	B	TEFC	3.8

### DYNAFLUX FHP AC INDUCTION WORM GEARED MOTORS

#### FLANGE MOUNTING.

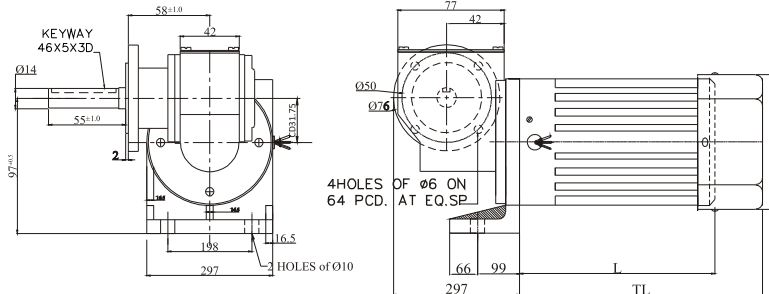

#### FOOT MOUNTING

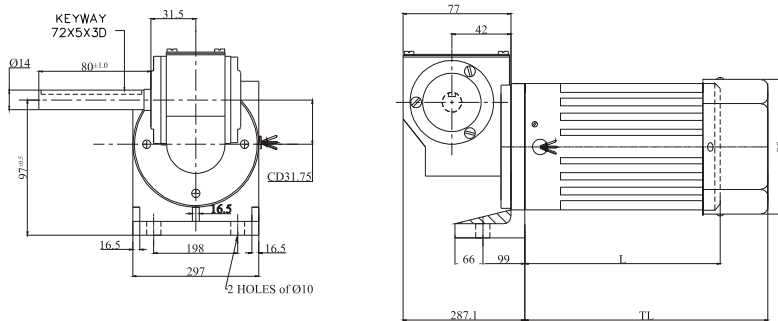

#### RATED TORQUE OF WORM GEAR HEAD

Application	RATIO	O / P RPM	TORQUE Kg-cm						40 Watts TL	60 Watts TL	90 & 120 Watts TL	180 & 200 Watts TL
			40 W	60 W	90 W	120 W	180 W	200 W				
40,60,90, 120,180 Watts MOTOR	WORM GEAR											
	10	125	15	20	30	40	50	60	126	130	145	
	16	75	25	40	60	80	100	120	126	130	145	
	24	50	40	60	80	100	120	150	126	130	145	
	48	25	70	80	120	140	180	200	126	130	145	
	WEIGHT (KG)		3.9	3.9	4.4	4.4	4.8	4.8				